

DATASHEET

Specifications rev. 5 - 09th April 2013

P/N 400-018 Monitoring Relay

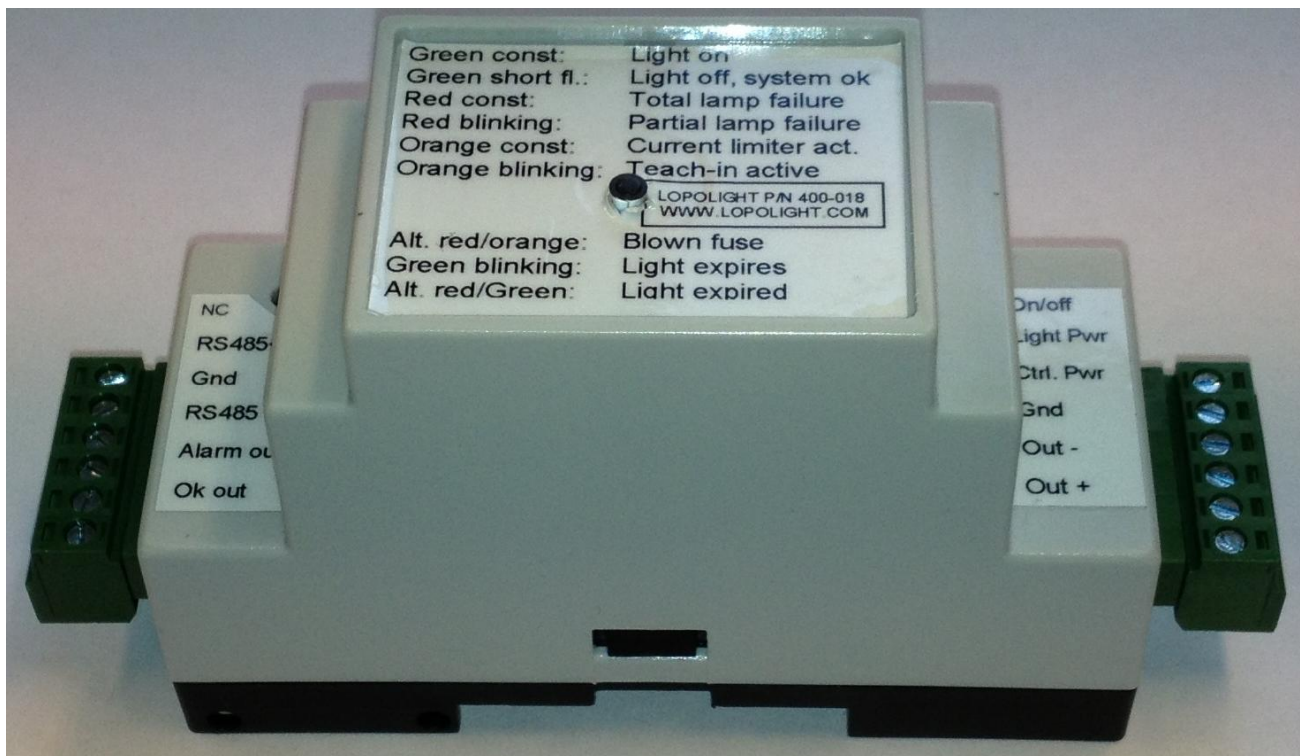

Description:

The Lopolight Monitoring Relay (LMR) is able to monitor Lopolight Navigation lights very accurately and will detect whether the light is operational, has a partial fault or a complete fault – whatever the reason.

The LMR will learn the profile of the navigation light it is set to monitor and will follow it through its life, also indicating when the light is getting too old and must be replaced.

The LMR offers both a manual panel connection which has priority and a communication channel for control from a computer via RS485.

Number of lights controlled by 1 Monitoring Relay: one (1)

The LMR can only be used to monitor Lopolight navigation lights. Designed for use in all vessel types and sizes to conform with EN 60945; MSC.253(83) and Lloyds Register Rules and Regulations for the Classification of Ships

Approved by Lloyds Register for use in ENV1 “Bridge and Deck zone, Cert # 12/70035

Physical dimensions:

Form: M36 DIN-rail enclosure
Size: 110 x 32 x 58 mm (L x W x H)
Weight: 65 gram

Controller output for bridge navigation light panel:

Alarm out: 20 mA output (max 5VDC) – activated if light fails, fully or partially
Ok out: 20 mA output (max 5VDC) – activated when ok signal received from light
Gnd: common ground

Controller input:

On/off: Switches the light on when connected to GND
GND: (0V)
Light pwr: + 10,5-32,0 VDC power supply to navlight
Controller pwr: + 10,0-32,0 VDC power supply to controller

Controller output for light:

Out -: - (0V) to navlight.
Out +: + 10-32 VDC for light
Both positive and negative outputs are switched (MOS-FET technology)

Controller diagnostic signals (light on top of controller):

Green constant on: Light on, controller ok
Green short flash: Light off, controller ok
Red constant: Total light failure, controller ok
Red blinking: Partial light failure, controller ok
Orange constant: Current limiter active (short circuit), controller ok
Orange blinking: Teach-in active, controller ok
Alternating red/orange: Blown fuse/controller failure
Green blinking: Light expires soon (more than 48.000 operating hrs.)
Alternating red/green: Light expired (more than 50.000 operating hrs.)

Current limiter:

The LMR has built-in over current protection. This function will activate if the current supplied to the navigation light is over 0,95 Amp. When a short is detected then the LMR will imidiately cut supply. It will automatically reset after 30 sec. If the short is still present, the procedure will be repeated.

Teach in function:

The LMR must learn the characteristics of the individual light. The following procedure must be followed after first time installation:

Turn on Lopolight navigation light by connecting J1 pin 6 to GND
 [Status LED turns red.]

Wait more than 10 seconds to ensure that the light has completed start-up sequence. Press and release internal teach-in button under the small hole in the housing, using a thin plastic pin. The status LED will flash orange. Wait app. 5 seconds until status led changes to green. The controller has now stored the values for the light it is set to monitor.

If new light is installed or the LMR is connected to a new light, a new teach-in procedure is required.

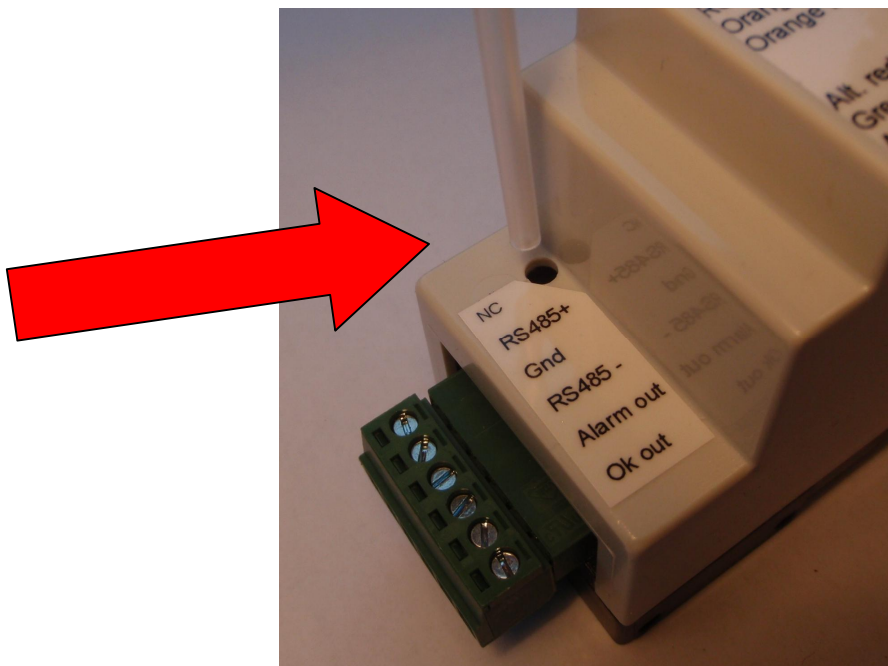

Toggle / Switch input:

The LMR can turn on the Lopolight navigation light in two different ways.
 1) by pulling J1-pin 6 down constantly (connect to GND via toggle type switch)
 2) by pulling J1-pin 6 down once (connect to GND via push-button).
 (Activating J1/6 once more will change the output state again.)

The push button mode (2) is selected by setting bit 8 on the dip-sw. to ON

Handling multiple LMR alarms in same panel:

If a number of LMR's must control the same acoustic alarm in the panel, then the Lopolight Alarm Multiplexer unit (P/N: 400-025) is recommended. Please refer to separate datasheet.

Wiring:

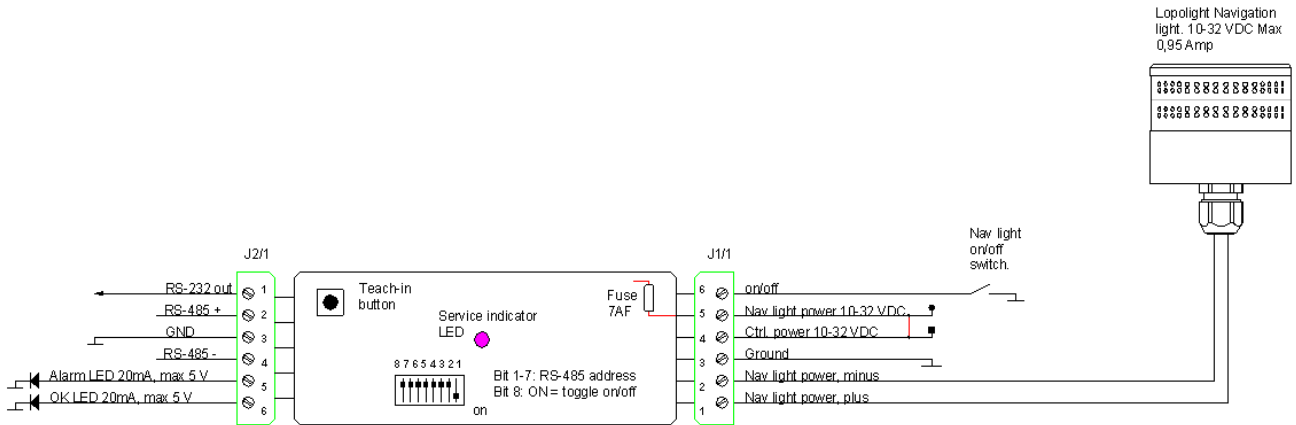

RS-485 communication: (Please refer to protocol description for details)

The LMR can be connected to other LMR's in an RS-485 network. All units in the network can be controlled to turn on their respective lights solely by means of data telegrams. The individual units will report any irregularity on the RS-485 network. The individual units in a network must be assigned to a unique address – settable on the internal 6 bit dipswitch. Bit 8 on the dipswitch **MUST** be set to “on” to enable RS-485 control. (and thus also enable toggle sw. control)

The following commands can be sent to the LMR:

- “Turn on lamp”
- “Turn off lamp”
- “Status req.”

The LMR can return the following information to the network after turn on command:

- “ok” (defined by minimum 90 % of all LED's working)
- “not ok” (defined by less than 90 % of all LED's working)
- “over 48.000 h” signal
- “over 50.000 h” signal
- “system ok – lamp turned off”

Priority:

Hardware interface (pushbutton switch) will generally have priority over RS-485 interface. This means that if the LMR is turned on or off via data command, then the output state can be toggled by a (GND) pulse on J1 pin 6.

Maintenance:

In case of malfunction the unit must be replaced completely.

The connectors are disconnected as shown here:

Old unit is lifted of DIN rail and new mounted in the orientation as the old.

Teach in procedure must be performed, see above for instructions.

If toggle switch mode is used and/or RS-485 communication is used the dip switch settings of the old controller **MUST** be transferred to the new unit.

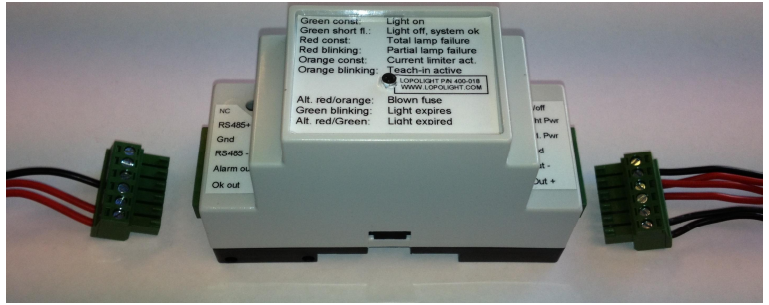

Installation:

This unit is designed and tested for use as a component in a navigation light control and monitoring system.

The navigation light control and monitoring system as a whole must be enclosed and protected against moisture as per class requirements